

SECTION 8 - STEERING/FRAME

TABLE OF CONTENTS

8

Steering Post/Tie Rods	8-2
Handlebar Grip	8-4
Steering Knuckles	8-4
Measuring/Adjusting Toe-In/Toe-Out.....	8-8
Body Panel Assembly Schematic.....	8-10
Front Rack.....	8-10
Front Bumper Assembly	8-11
Front Fender/Side Panels.....	8-12
Fender Flares/Extensions	8-13
Footrests	8-14
Belly Panel	8-14
Exhaust System	8-14
Rear Rack	8-15
Rear Fender	8-15
Adjusting Headlight	8-16
Taillight Assembly.....	8-16
Seat.....	8-17

Steering Post/ Tie Rods

REMOVING

1. Remove the seat (see Seat in this section).
2. Remove the storage compartment cover; then remove the cap screws securing the storage compartment/air filter cover.



KX038

3. Remove the cotter pin and slotted nut securing each tie rod end to the steering post arm. Remove the tie rod ends from the arm.

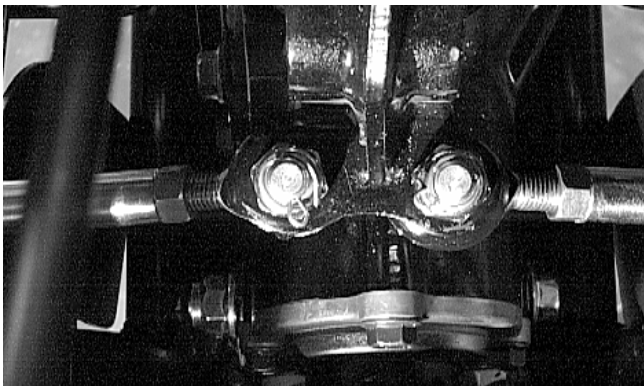

AF778D

4. Remove the cotter pin and slotted nut securing the side tie rod ends to the knuckles. Remove the tie rod ends from the knuckles; then remove the tie rods.
5. Remove the cap screws securing the steering post bearing flange.

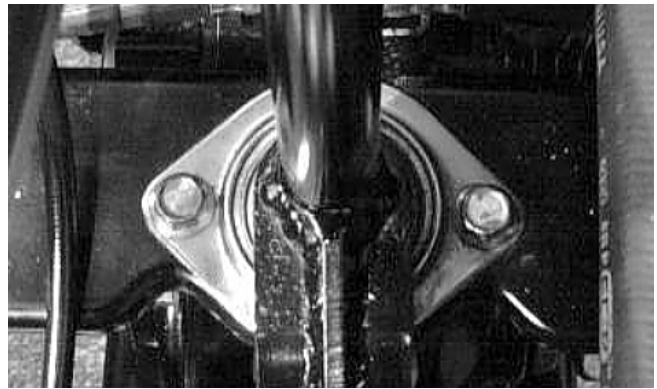

AL600D

6. Remove the nylon fasteners securing the instrument pod.
7. Remove the retaining nut securing the ignition switch; then remove the instrument pod.
8. Remove the four cap screws securing the handlebar caps (blocks) to the steering post; then move the handlebar out of the way.

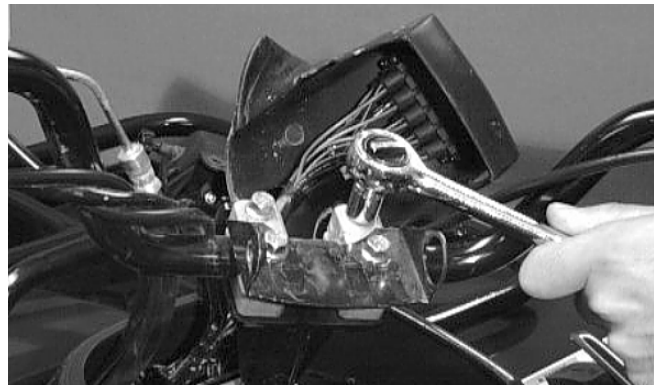

AL614D

9. Remove the two cap screws securing the upper steering post bearing housings to the frame.

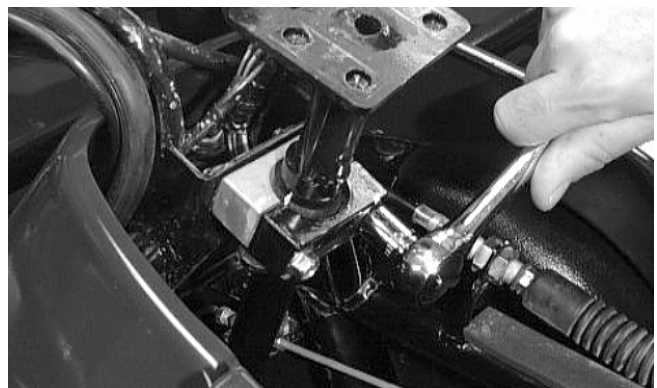

AL619D

10. Remove the steering post.

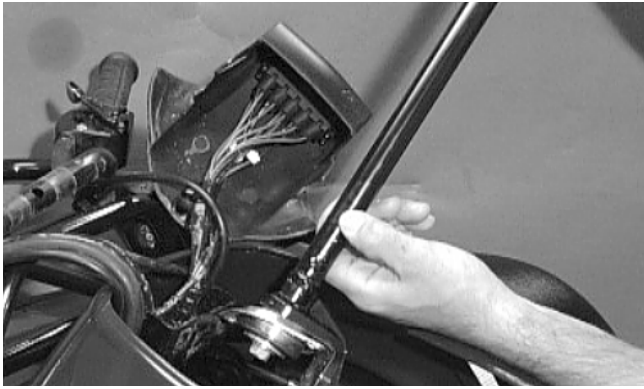

AL618D

CLEANING AND INSPECTING

■ **NOTE:** Whenever a part is worn excessively, cracked, or damaged in any way, replacement is necessary.

1. Wash the tie rod ends in parts-cleaning solvent. Dry with compressed air. Inspect the pivot area for wear. Apply a low-temperature grease to the ends.

WARNING

Always wear safety glasses when using compressed air.

2. Inspect the tie rods for damaged threads or wear.
3. Inspect the tie rods for cracks or unusual bends.
4. Inspect all welded areas for cracks or deterioration.
5. Inspect the steering post and steering-post brackets for cracks, bends, or wear.
6. Inspect the bearing halves, bearing caps, and bearing housings for cracks or wear.
7. Inspect the handlebar tube for cracks, wear, or unusual bends.
8. Inspect the handlebar grips for damage or wear.

INSTALLING

1. Place the steering post into position; then place the upper steering post bearings and housings on the steering post and install the two cap screws through the housings and into the frame. Tighten the cap screws to 2.8 kg-m (20 ft-lb).

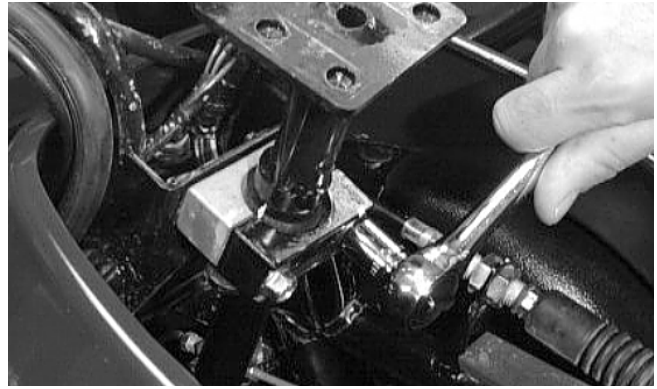

AL619D

2. Place the handlebar into position and secure with the handlebar caps (blocks). Tighten the four cap screws to 2.8 kg-m (20 ft-lb).



KX385

3. Place the ignition switch into position; then place the instrument pod into position and secure with the ignition switch retaining nut.



KX386

4. Secure the instrument pod with the four nylon fasteners.
5. Place the steering post bearing flange into position. Secure with the cap screws tightened to 2.8 kg-m (20 ft-lb).

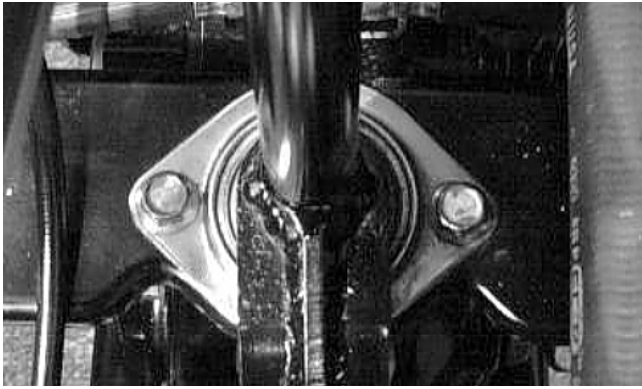

AL600D

6. Insert the tie rod ends into the knuckles; then install the slotted nuts and tighten to 4.2 kg-m (30 ft-lb). Lock the nuts with new cotter pins.
7. Insert the tie rod ends into the steering post arm; then install the slotted nuts and tighten to 4.2 kg-m (30 ft-lb). Lock the nuts with new cotter pins.

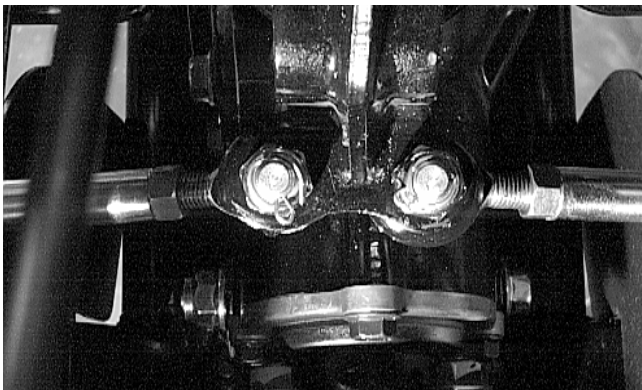

AF778D

8. Place the storage compartment/air filter cover into position; then secure with the two cap screws.

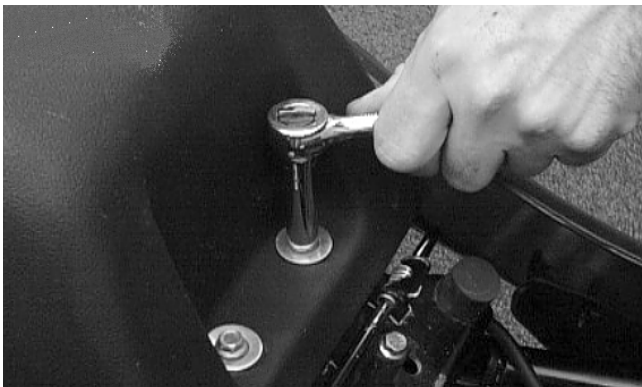

AL617D

9. Install the storage compartment cover with the four snap fasteners.
10. Install the seat (see Seat in this section).

Handlebar Grip

REMOVING

1. Remove the plug from the head of the rivet.
2. Using a 1/8-in. drill bit, drill out the rivet.
3. Using compressed air between the grip and the handlebar, twist the grip back and forth until it slides free of the handlebar.

INSPECTING

■ **NOTE:** Whenever a part is worn excessively, cracked, or damaged in any way, replacement is necessary.

1. Inspect the grip for wear, cuts, or cracks.
2. Inspect the grip for deterioration.

INSTALLING

■ **NOTE:** Before installing a grip, use contact spray or alcohol to clean the inside of the grip and the handlebar of glue residue, oil, or any other contaminant.

1. Apply a liberal amount of Handlebar Grip Adhesive (p/n 0636-071) to the inside of the grip.
2. Align the rivet hole in the grip with the rivet hole in the handlebar; then align the notch (inside the grip) with the slot in the handlebar and slide the grip onto the handlebar until it is fully seated.
3. Wipe off any excess glue; then secure the grip with a new rivet.
4. Install the plug on the head of the rivet.

Steering Knuckles

REMOVING AND DISASSEMBLING

1. Secure the ATV on a support stand to elevate the wheel; then remove the wheel.

 **WARNING**

Make sure the ATV is solidly supported on the support stand to avoid injury.

2. Remove the wheel cap from the hub; then remove the cotter pin from the nut.

3. Remove the nut securing the hub. Account for a washer and a hub seal.
4. Remove the brake caliper.
5. Remove the hub assembly.
6. Remove the cotter pin from the tie rod end and remove the tie rod end from the knuckle.
7. Remove the two cap screws securing the ball joints in the knuckle.
8. Tap the ball joint end out of the knuckle; then remove the knuckle.
9. Remove the seal from the knuckle.

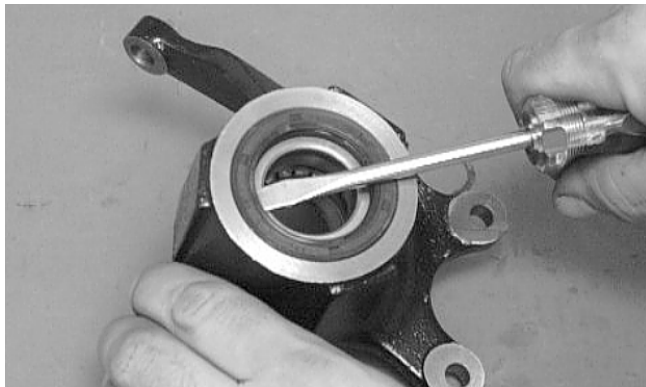

AF725D

10. Remove the bearing retainer.

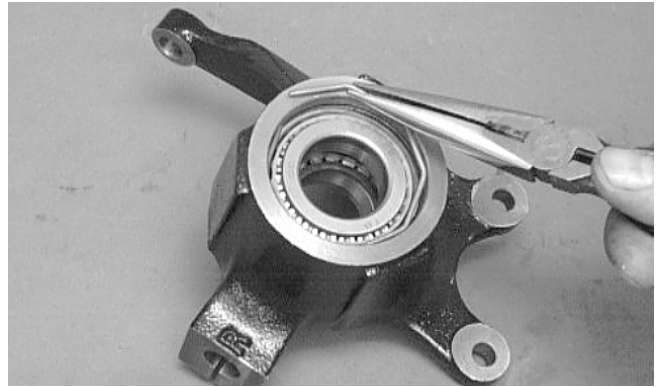

AF726D

11. Remove the bearings.

⚠ CAUTION

Use extreme care when removing the bearing. If the bearing is allowed to fall, it will be damaged and will have to be replaced.

CLEANING AND INSPECTING

■ **NOTE:** Whenever a part is worn excessively, cracked, or damaged in any way, replacement is necessary.

1. Clean all knuckle components.
2. Inspect the bearing for pits, gouges, rusting, or premature wear.
3. Inspect the knuckle for cracks, breaks, or porosity.
4. Inspect threads for stripping or damage.

ASSEMBLING AND INSTALLING

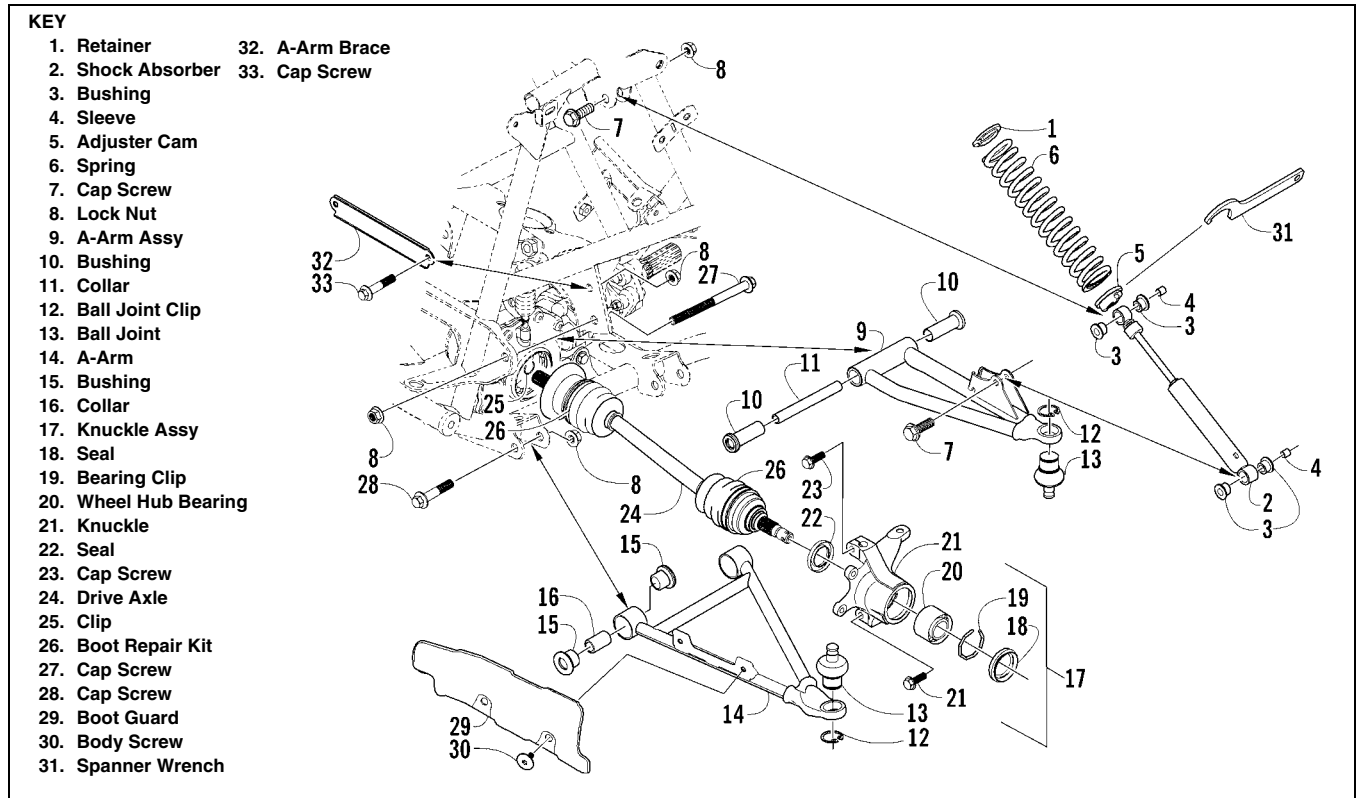

0739-292

1. Install the bearing.
2. Install the bearing retainer.

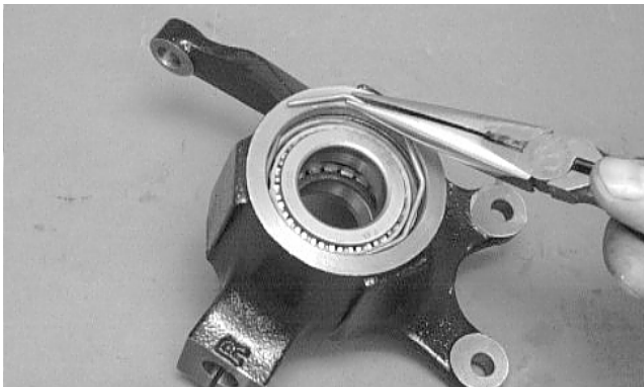

AF726D

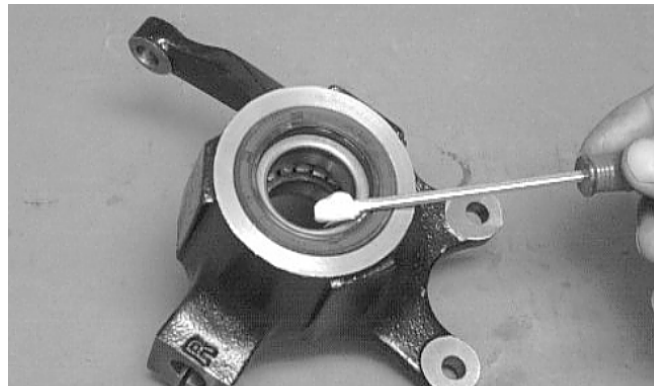

AF724D

5. Install the knuckle to the upper and lower ball joints and secure with the two cap screws. Tighten to 4.8 kg-m (35 ft-lb).

3. Install a new seal into the knuckle making sure the seal is flush with the knuckle.
4. Apply grease to the seal.



AF760D

6. Install the tie rod end and secure with the nut. Tighten to 4.2 kg-m (30 ft-lb); then install a new cotter pin and spread the pin.

■NOTE: During assembling, new cotter pins should be installed.

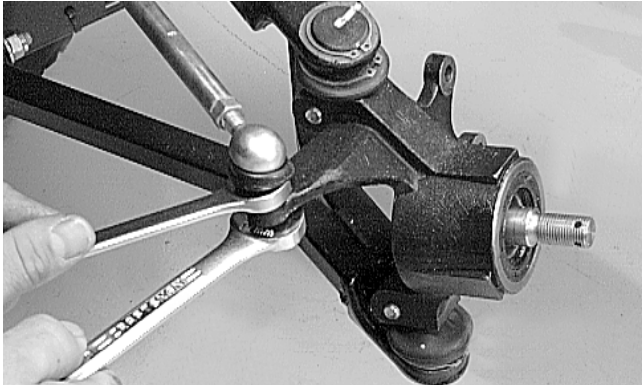

AF759D

7. Apply a small amount of grease to the hub sealing area and on the splines.

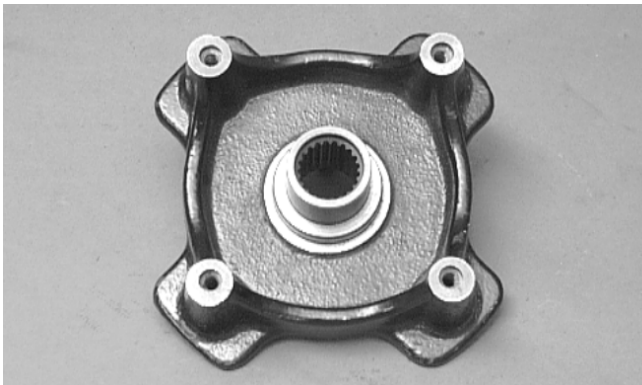

AF736D

8. Install the hub assembly onto the splines of the shaft.



CD009

9. Place the washer onto the shaft; then secure the hub assembly with the nut. Tighten only until snug.

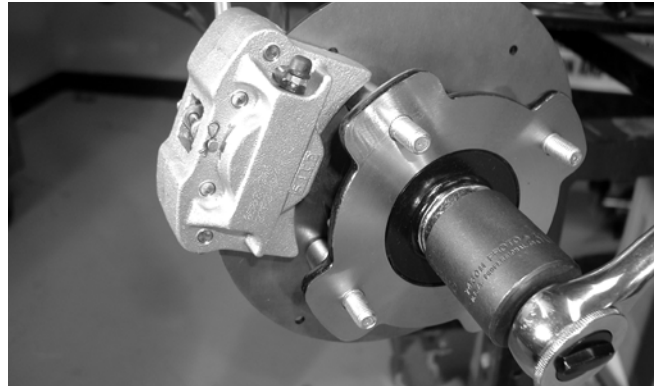

CD015

10. Secure the brake caliper to the knuckle with the two cap screws. Tighten to 2.8 kg-m (20 ft-lb).

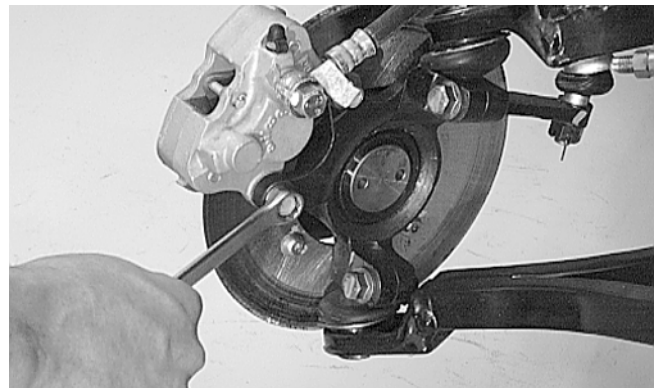

AF746D

11. Secure the hub nut (from step 10) to the shaft. Tighten to 10.4 kg-m (75 ft-lb).

12. Install a new cotter pin and spread the pin to secure the nut.

13. Install the wheel cap.

14. Install the wheel and tighten to 5.5 kg-m (40 ft-lb).



CD006

15. Remove the ATV from the support stand.

Measuring/Adjusting Toe-In/Toe-Out

1. Thoroughly wash the ATV to remove excess weight (mud, etc.).
2. Refer to the specifications and ensure the tires are properly inflated to the recommended pressure.

■ **NOTE:** Ensure the inflation pressure is correct in the tires or inaccurate measurements can occur.



CD005

3. Place the ATV in a level position taking care not to push down or lift up on the front end; then turn the handlebar to the straight ahead position.

■ **NOTE:** When measuring and adjusting, there should be a normal operating load on the ATV (without an operator but with Arctic Cat approved accessories).

4. Measure the distance from the outside edge of each handlebar grip to the seat catch brackets.

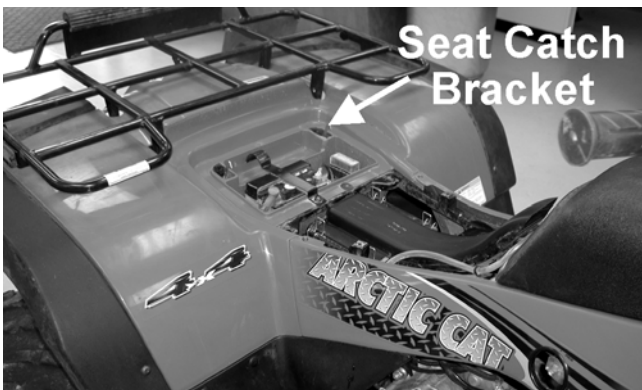

CD012A

5. Adjust the handlebar direction until the two measurements are equal; then secure the handlebar to the rear rack using tie-down straps.

■ **NOTE:** Care must be taken not to allow the handlebar to turn while securing it.



CD014

6. Measure the distance from the inside of each front rim to the lower frame tube.

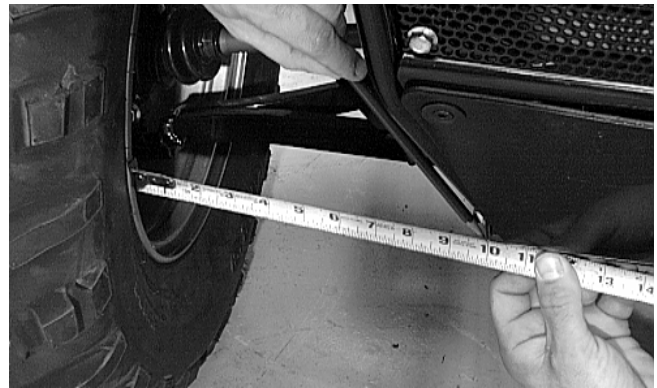

AF785D

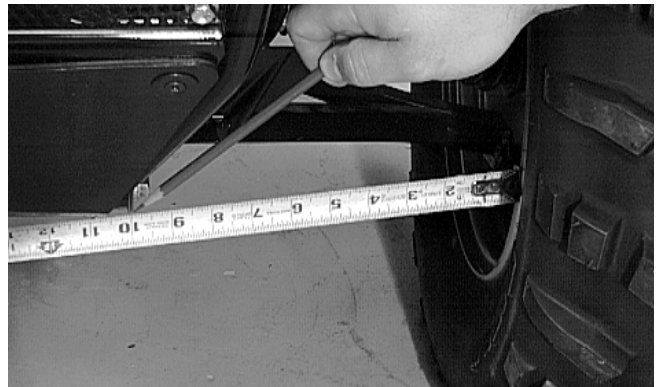

AF786D

■ **NOTE:** The distances from the inside rims to the frame tubes should be equal. If the measurements are equal, proceed to step 8; if the measurements are not equal, proceed to step 7.

7. To make the measurements equal, loosen the appropriate tie rod jam nuts and adjust accordingly; then proceed to step 8.

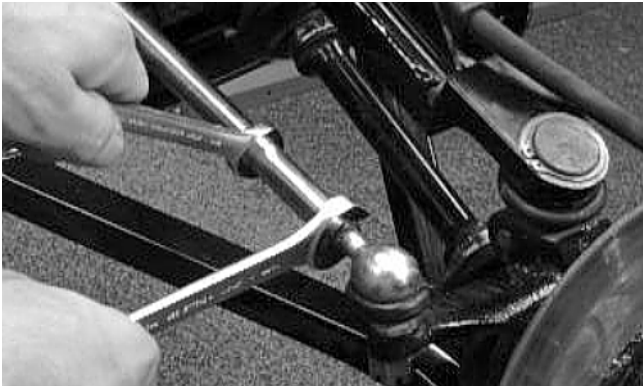

AF617D

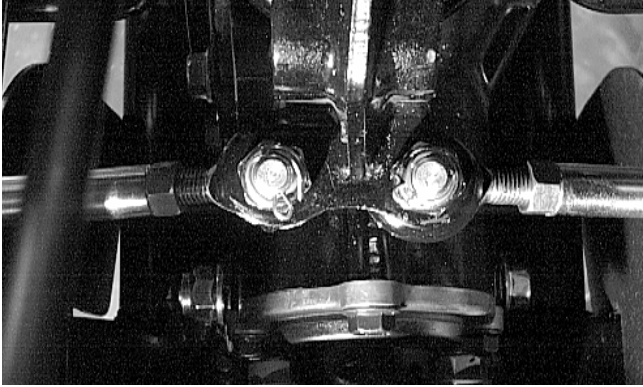

AF778D

■ **NOTE:** The front wheels do not have to be removed to adjust the tie rod. Also, care should be taken not to disturb the handlebar position.

- Using a permanent marker of some type, mark the center of each front tire (at a height parallel to the belly panel).



AF789D

- Measure the overall width of the front tires (at a height parallel to the belly panel) at the front side; then record the measurement.
- Push the ATV forward until the marks are parallel to the belly panel on the back side; then measure the overall width of the front tires at the rear side.



CD013

- The difference in the measurements must show 6.4 mm (1/4 in.) toe-in (the front measurement 6.4 mm (1/4 in.) less than the rear measurement).

■ **NOTE:** The 6.4 mm (1/4 in.) toe-in difference is per side.

- If the difference in the measurements does not show a 6.4 mm (1/4 in.) toe-in, adjust both tie rods equally in until within specification.

■ **NOTE:** Prior to locking the jam nuts, make sure the ball joints are at the center of their normal range of motion and at the correct angle.

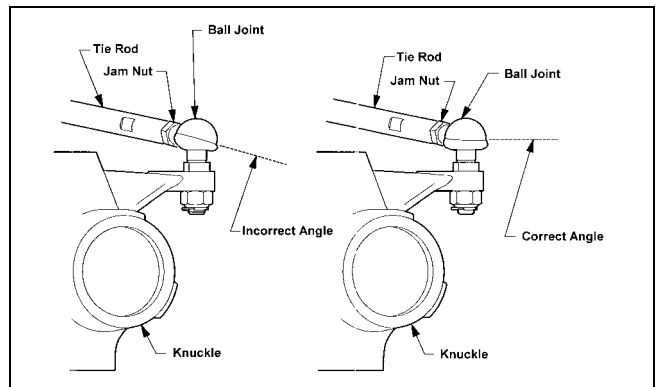

733-559A

Body Panel Assembly Schematic

KEY

- | | |
|-------------------------|------------------------|
| 1. Fender Panel | 29. Fender Panel |
| 2. Access Cover | 30. Cable Tie |
| 3. Rack | 31. Fender Panel |
| 4. Cap Screw | 32. Self-Tapping Screw |
| 5. Reflector | |
| 6. Cap Screw | |
| 7. Flare | |
| 8. Stamped Nut | |
| 9. Body Screw | |
| 10. Speed Nut | |
| 11. Machine Screw | |
| 12. Storage Compartment | |
| 13. Cover | |
| 14. Cover Hinge | |
| 15. Self-Tapping Screw | |
| 16. Grommet | |
| 17. Clip | |
| 18. Washer | |
| 19. Side Panel | |
| 20. Heat Shield | |
| 21. Shoulder Screw | |
| 22. T-Nut w/Teeth | |
| 23. Rivet | |
| 24. Flare Extension | |
| 25. T-Nut w/Teeth | |
| 26. Machine Screw | |
| 27. Kick Panel | |
| 28. Plastic Rivet | |

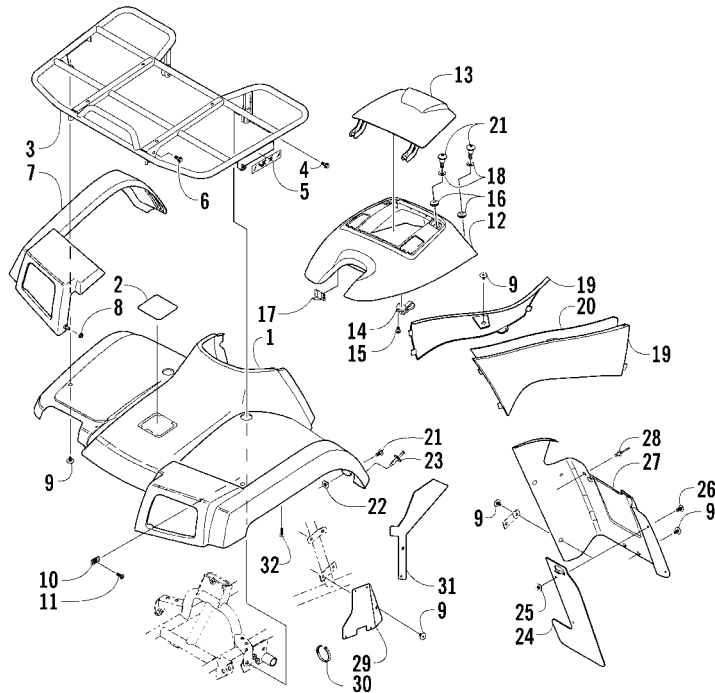

0739-033

Front Rack

REMOVING

1. Remove the two cap screws securing the fenders to the rack.



AF600DA

2. Remove the cap screws securing the rack to the frame and front bumper assembly.

3. Remove the front rack from the ATV.

CLEANING AND INSPECTING

■ **NOTE:** Whenever a part is worn excessively, cracked, or damaged in any way, replacement is necessary.

1. Clean all rack components with parts-cleaning solvent.
2. Inspect all welds for cracking or bending.
3. Inspect threaded areas of all mounting bosses for stripping.
4. Inspect for missing decals and/or reflectors.

INSTALLING

1. Place the rack into position on the frame and bumper. Start the cap screws and finger-tighten only.
2. Install the two cap screws securing the rack to the fenders. Tighten all hardware securely.

Front Bumper Assembly

REMOVING

■ **NOTE:** Remove the headlights with the front bumper.

1. Remove the main wiring harness connectors from the four headlights.
2. Remove the two screws securing the grille to the front bumper.
3. Remove the two push nuts securing the fender extension to the front bumper. Push the fender extension studs out of the front bumper.



CC856

4. Remove the four cap screws securing the front skid plate to the front bumper.
5. Remove the two cap screws securing the front bumper to the frame.



CC858

6. Remove the two cap screws securing the front bumper to the front bumper supports.

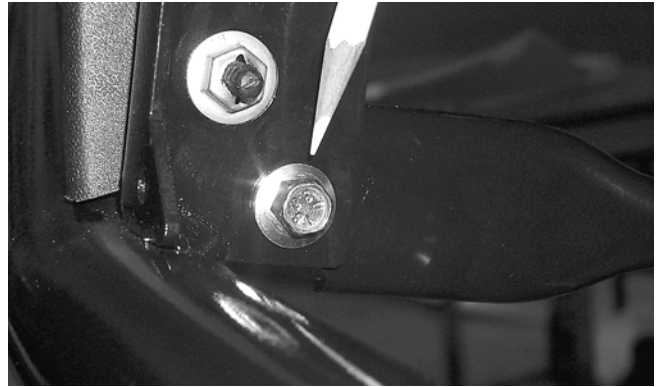

CC857

7. Remove the front bumper with headlights.

CLEANING AND INSPECTING

■ **NOTE:** Whenever a part is worn excessively, cracked, or damaged in any way, replacement is necessary.

1. Clean all bumper components with parts-cleaning solvent.
2. Inspect all welds for cracking or bending.
3. Inspect threaded areas of all mounting bosses for stripping.
4. Inspect the wiring harness and headlights for damage.
5. Inspect the screen for damage or air-flow obstructions.

INSTALLING

1. Place the front bumper assembly into position on the frame and secure with four cap screws. Tighten securely.
2. Secure the front skid plate to the front bumper with the four cap screws. Tighten securely.
3. Place the two fender extension studs through the front bumper and secure with the existing push nuts.

8



CC856

4. Position the grille in the front bumper and secure.
5. Connect the wiring to each of the headlights.

Front Fender/ Side Panels

REMOVING

1. Remove the front rack (see Front Rack in this section).
2. Remove the three cap screws securing the two side panels to the frame and rear fenders; then remove the side panels.
3. Using a small flat-blade screwdriver, carefully remove the retaining pin securing the gear shift knob to the shift lever; then remove the knob from the lever.

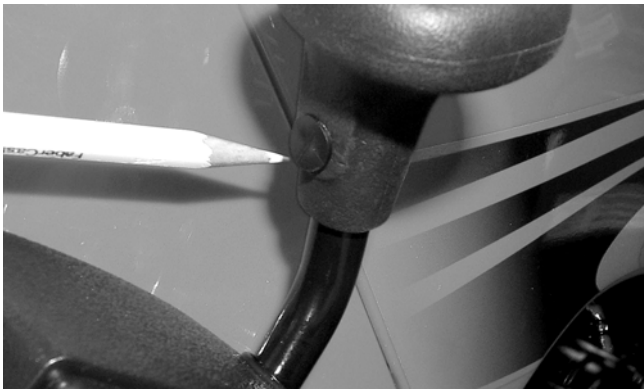

CC852

4. Remove the three machine screws securing the gear shift linkage cover to the fender and remove the cover.

■ **NOTE:** The cover is located inside the left-front wheel well.



CC851

5. Remove the nut securing the drive selector linkage. Account for a washer and bushing.

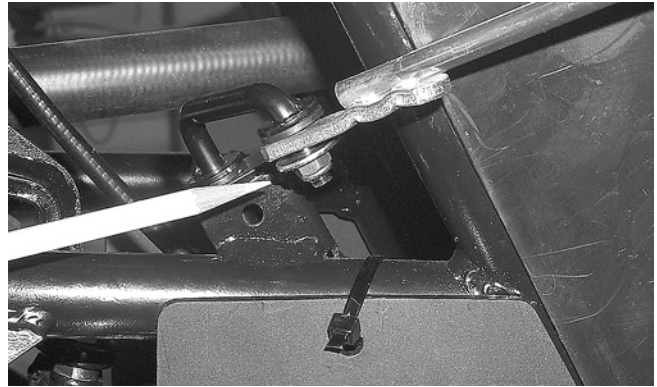

CC853

6. Remove the six cap screws securing the fender to the frame.

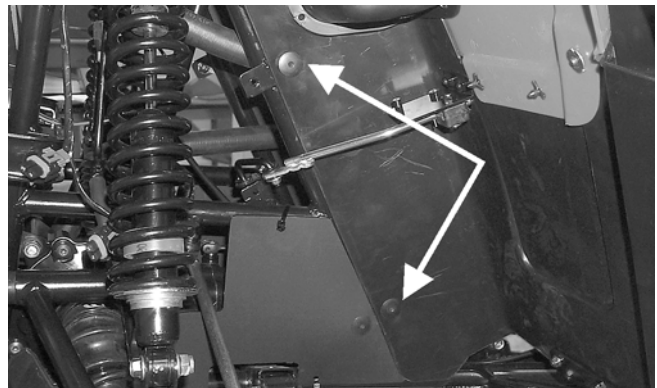

CC854A

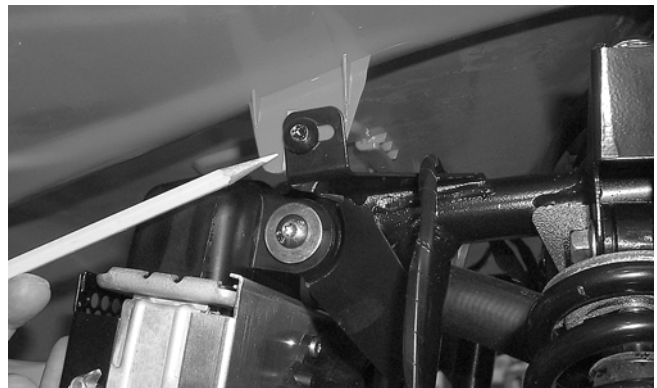

CC855

7. Remove the four cap screws and nuts securing the fender to the footrests.

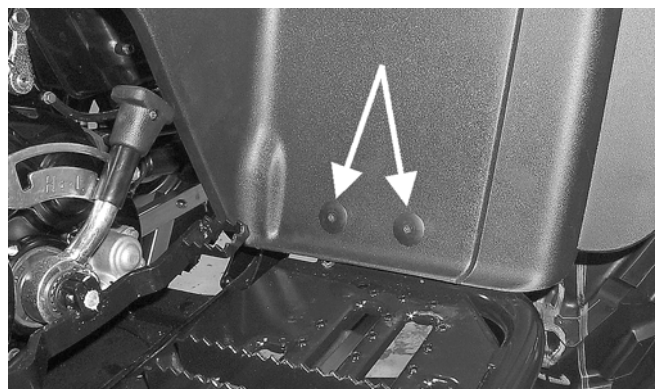

CC861A

8. Disconnect the wires from the accessory plug (if equipped); then remove the accessory plug from the fender.
9. Remove the fenders from the ATV.

CLEANING AND INSPECTING

■ **NOTE:** Whenever a part is worn excessively, cracked, or damaged in any way, replacement is necessary.

1. Clean all fender components with part-cleaning solvent and soap and water.
2. Inspect fenders for cracks and/or loose rivets.
3. Inspect for any missing decals.

INSTALLING

1. Place the fenders into position on the ATV.
2. Install the accessory plug (if equipped) into the fender; then connect the two accessory plug wires.

■ **NOTE:** The accessory plug red wire goes on the center connector.

3. Install the cap screws (five per side) securing the fenders to the frame and footrests and finger-tighten; then tighten the ten fasteners securely.
4. Connect the drive selector linkage using existing hardware. Tighten securely.



KX057

5. Install the gear shift linkage cover in the left-front fender well. Tighten securely.



CC851

6. Place the gear shift knob into position on the shift lever and secure with the retaining pin.
7. Place the side panels into position and secure.
8. Install the front rack (see Front Rack in this section).

Fender Flares/ Extensions

REMOVING

1. Using a side-cutter, remove the appropriate plastic rivets.

■ **NOTE:** To remove a front extension, first remove the grille; then remove the push nuts securing the extension to the bumper.

2. Remove the cap screws securing the extensions or flares to the frame and footrest.
3. Remove the self-tapping screws securing the extension to the fender.

INSTALLING

1. Place the flare or extension into position. Using the Plastic Rivet Setter (p/n 0444-056), secure with Plastic Rivets (p/n 0423-046) or suitable substitute.
2. Secure the extensions or flares with the cap screws and self-tapping screws.

Footrests

REMOVING

1. Remove the cap screws securing the fender extension to the footrest. Account for all cap screws and one nut.

■ **NOTE:** It will be easiest to remove the front inner cap screw by removing the nut from inside the wheel well.

2. On the right-side footrest, disconnect the foot brake switch from the main wiring harness.
3. Remove the cap screws securing the footrest to the frame; then remove the footrest.

■ **NOTE:** On the right-side footrest, it will be necessary to remove the foot brake cable from the brake pedal.

CLEANING AND INSPECTING

■ **NOTE:** Whenever a part is worn excessively, cracked, or damaged in any way, replacement is necessary.

1. Clean the footrest in parts-cleaning solvent.
2. Inspect the footrest weldments for cracks or unusual bends.
3. Inspect all tubing for cracks or unusual bends.

INSTALLING

1. Connect the foot brake cable to the brake pedal (right-side footrest).
2. Place the footrest into position on the frame and loosely secure with the four cap screws.
3. Secure the fender extension to the footrest with existing hardware. Tighten securely.
4. Tighten the 10 mm footrest cap screws (from step 2) to 5.5 kg-m (40 ft-lb); then tighten the 8 mm cap screws (from step 2) to 2.8 kg-m (20 ft-lb).
5. Connect the foot brake switch to the main wiring harness. Ensure that the harness is properly secured to the frame and away from any moving parts.

Belly Panel

REMOVING

1. Remove the machine screws and shoulder washers securing the belly panel to the underside of the frame.
2. Remove the belly panel.

INSTALLING

1. Place the belly panel into position on the underside of the frame.
2. Install the machine screws and shoulder washers. Tighten securely.

Exhaust System

REMOVING MUFFLER

1. Remove the cap screws securing the muffler to the frame and account for all mounting hardware.
2. Loosen the clamp at the muffler/exhaust pipe juncture; then remove the nuts securing the rear exhaust pipe to the cylinder and remove the muffler.



CH056D

INSPECTING MUFFLER

■ **NOTE:** Whenever a part is worn excessively, cracked, or damaged in any way, replacement is necessary.

1. Inspect muffler externally for cracks, holes, and dents.
2. Inspect the muffler internally by shaking the muffler back and forth and listening for rattles or loose debris inside the muffler.

■ **NOTE:** For additional details on cleaning the muffler/spark arrester, see Section 2.

INSTALLING MUFFLER

1. Install the muffler on the frame and into the muffler/exhaust pipe juncture and rear cylinder exhaust port accounting for all mounting hardware.
2. Tighten cap screws securely; then tighten the juncture clamp and the nuts securing the exhaust pipe to the rear cylinder.

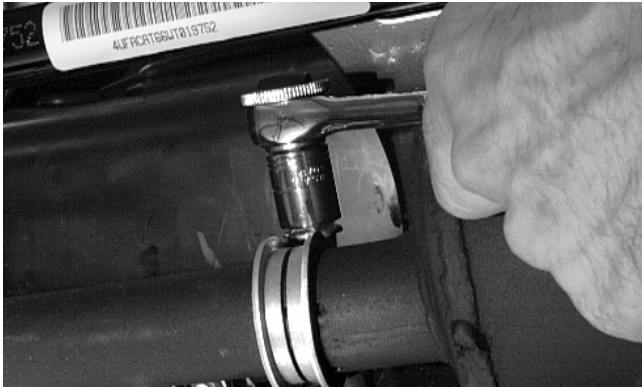

CH056D

Rear Rack

REMOVING

1. Remove the cap screws securing the rear rack to frame and rear fenders. Account for any washers.
2. Lift the rack upward and remove from the frame.

CLEANING AND INSPECTING

■ **NOTE:** Whenever a part is worn excessively, cracked, or damaged in any way, replacement is necessary.

1. Clean all rear rack components with parts-cleaning solvent.
2. Inspect all welds for cracking or bending.
3. Inspect threaded areas of all mounting bosses for stripping.
4. Inspect for missing decals and/or reflectors.

INSTALLING

1. Place the rack into position on the frame; then install the cap screws and any washers.
2. Tighten all fasteners securely.

Rear Fender

REMOVING

1. Remove the seat (see Seat in this section).
2. Remove the rear rack (see Rear Rack in this section).
3. Remove side panels (see Front Fender/Side Panels in this section).
4. Remove the cap screws and washers securing the fender to the frame and footrests.
5. Remove the battery hold-down and tool kit and disconnect the battery cables (negative cable first) and the vent hose; then remove the battery.
6. Route the battery cables and vent hose out of the fender through the hole at the bottom of the battery compartment.
7. Disconnect the taillight wiring harness three-prong connector; then remove the fender.

CLEANING AND INSPECTING

■ **NOTE:** Whenever a part is worn excessively, cracked, or damaged in any way, replacement is necessary.

1. Clean all rear fender components with parts-cleaning solvent and soap and water.
2. Inspect side panels, fender extensions, and rear fenders for cracks and loose rivets.
3. Inspect threaded areas of all mounting bosses for stripping.
4. Inspect for missing decals.

INSTALLING

1. Place the fender into position on the frame.
2. Route the battery cables and vent hose into the fender through the hole at the bottom of the battery compartment.
3. Secure the fender to the frame and footrests with existing cap screws and washers. Tighten securely.
4. Place the battery in position in the compartment; then install the vent hose, battery cables (positive cable first), the tool kit, and the battery hold-down.
5. Route the taillight wiring harness over the rear frame; then connect the three-prong connector.
6. Install the side panels (see Front Fender/Side Panels in this section).

7. Install the rear rack (see Rear Rack in this section).
8. Install the seat (see Seat in this section).

Adjusting Headlight

The headlights can be adjusted vertically and horizontally. The geometric center of the HIGH beam light zone is to be used for vertical and horizontal aiming.

1. Position the ATV on a level floor so the headlights are approximately 6.1 m (20 ft) from an aiming surface (wall or similar aiming surface).

NOTE: There should be an average operating load on the ATV when adjusting the headlight aim.

2. Measure the distance from the floor to the mid-point of each headlight.
3. Using the measurements obtained in step 2, make horizontal marks on the aiming surface.
4. Make vertical marks which intersect the horizontal marks on the aiming surface directly in front of the headlights.
5. Switch on the lights. Make sure the HIGH beam is on. DO NOT USE LOW BEAM.
6. Observe each headlight beam aim. Proper aim is when the most intense beam is centered on the vertical mark 5 cm (2 in.) below the horizontal mark on the aiming surface.

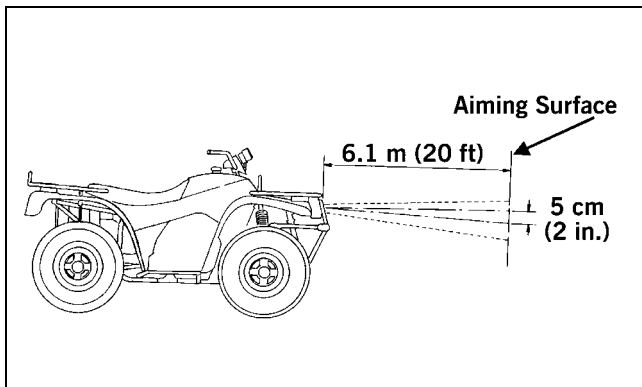

ATV-0070

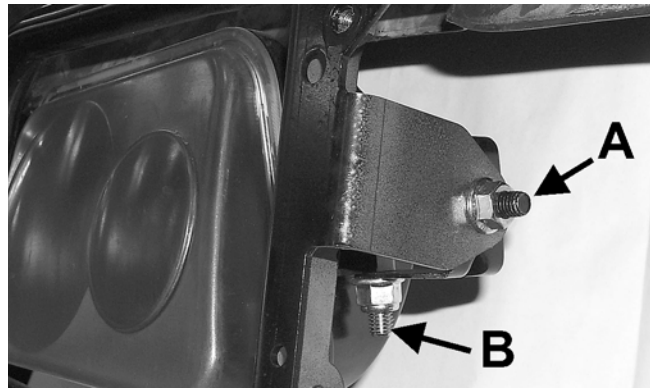

AF926A

7. Adjust each headlight until correct aim is obtained.

A. Horizontal - Loosen nut (A) and adjust for proper aiming. Tighten the nut securely.

B. Vertical - Loosen nut (B) and adjust for proper aiming. Tighten the nut securely.

⚠ WARNING

Do not operate the ATV unless the headlight beam is adjusted properly. An incorrectly adjusted beam will not provide the operator the optimum amount of light.

Taillight Assembly

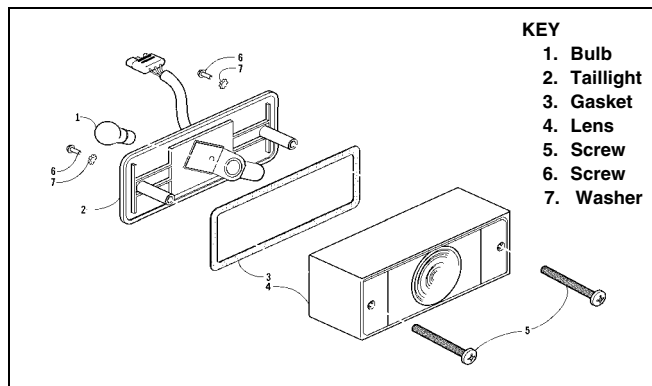

0732-336

REMOVING

1. Unplug the three-prong connector and free the taillight wiring harness from the frame.
2. Remove the torx-head cap screws securing the taillight assembly to the frame. Account for any washers.
3. Remove the taillight assembly.

INSPECTING

■NOTE: Whenever a part is worn excessively, cracked, or damaged in any way, replacement is necessary.

1. Inspect wiring harness, three-prong connector, lens, base, cap screws, and socket for damage.
2. Inspect all wires for corroding, pinching, and cracking.

3. Inspect the bulb for wattage, voltage, and proper operation.

INSTALLING

1. Place the assembly into position on the frame and secure with torx-head cap screws and any washers.
2. Tighten the cap screws securely.
3. Route the wiring harness over the rear frame; then connect the three-prong connector.

Seat

REMOVING/INSTALLING

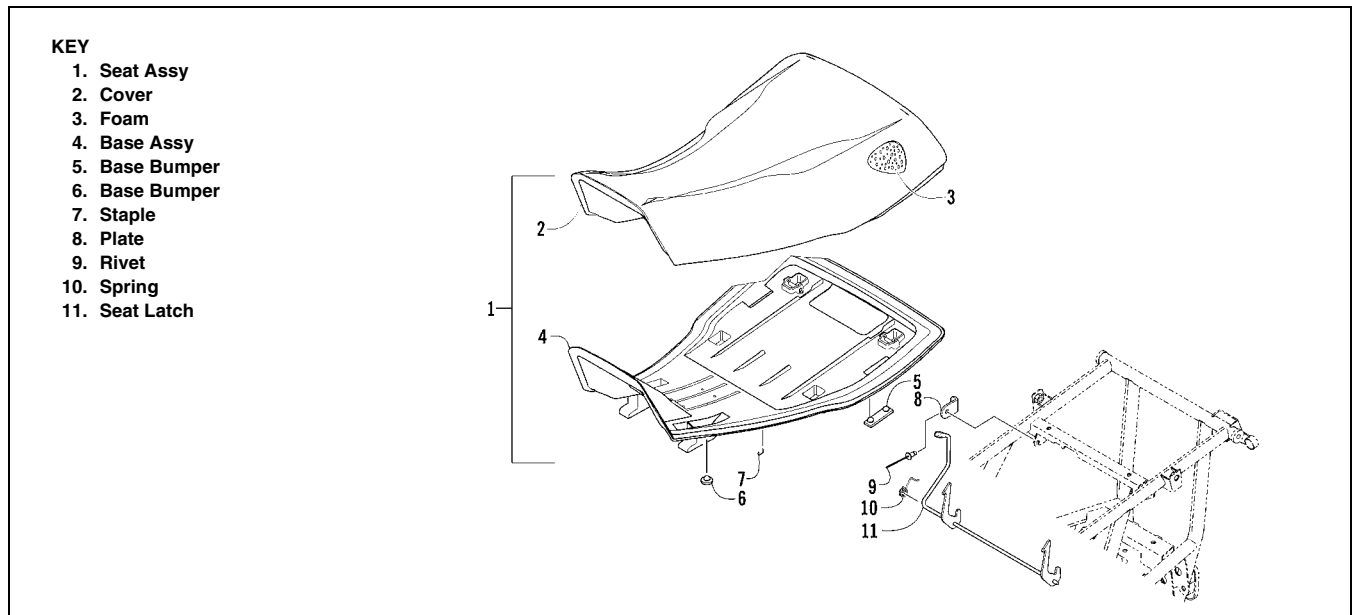

1. To remove the seat, pull the seat lock lever backward (located under the rear rack between the storage compartment and the frame). Raise the rear of the seat and slide it rearward.

2. To lock the seat into position, slide the front of the seat into the seat retainers and push down firmly on the rear of seat. The seat should automatically lock into position.

NOTES